

32'-10"

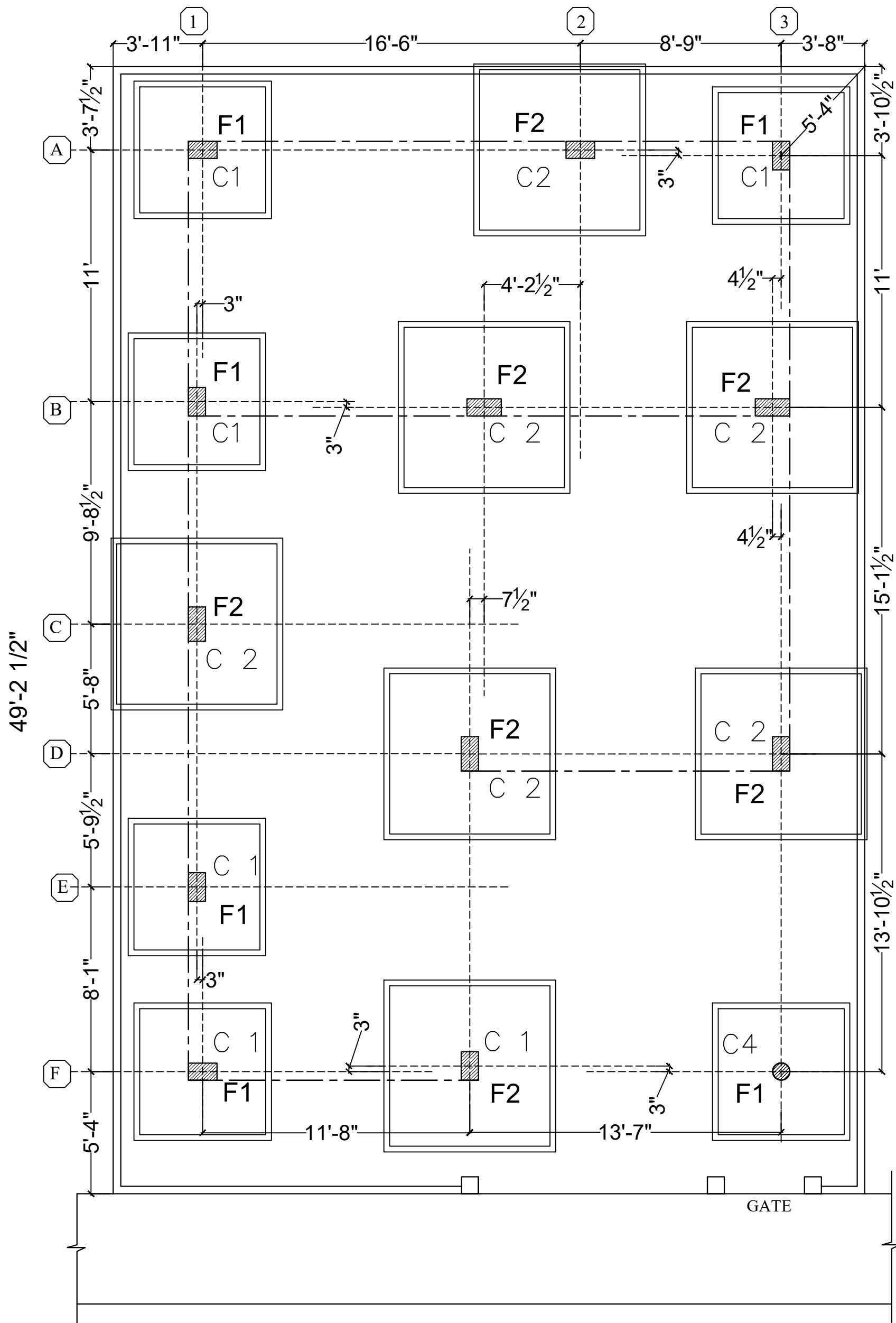

NOTE:
 1. REFER TO R.C.C DRAWINGS FOR FOOTINGS & FOUNDATIONS DETAILS
 2. DRAWING NOT TO SCALE. USE DIMENSIONS PROVIDED IN THE DRAWING.

----- COLUMN CENTER-LINE
 - - - - - LINE ALONG WHICH COLUMN FACES ALIGN

Description	Direction	Owners & Developers :	Date :	28/06/2018	Architects	Promoted by
TYPE- A1(3 BHK) COLUMN CENTER LINE PLAN		Modi Properties Pvt Ltd.	Prepared By :	Madhav Bhatt	Architectural Associates 8-1-385, R.P. Road, Secunderabad-3 ed.bashanandagar@hotmail.com	Modi Properties Pvt. Ltd. Phone:+91-40-66335551
		Project Name & Phase :	Approved By :	Soham Modi		
		AVR GULMOHAR HOMES	Scale :	N.T.S		