

PLAN

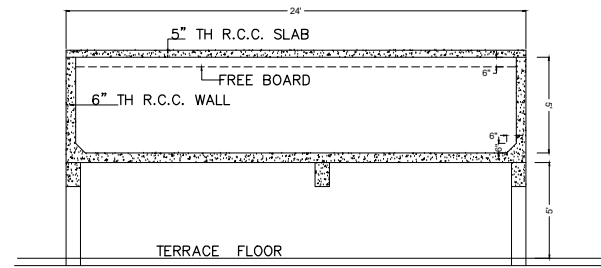

SECTION (X-X)

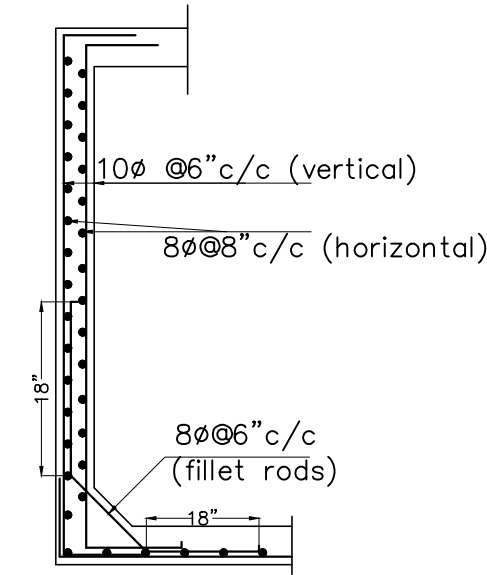

R.C.C WALL DETAILS

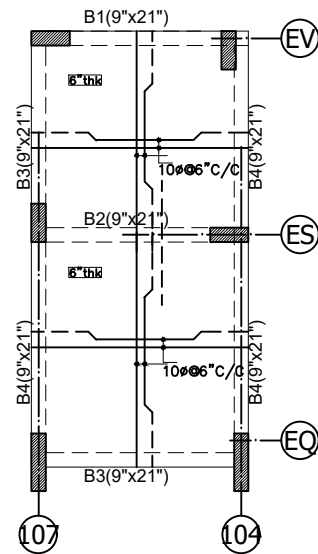

BOTTOM SLAB

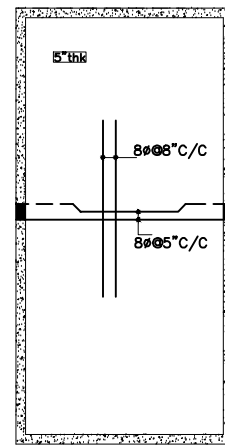

TOP SLAB

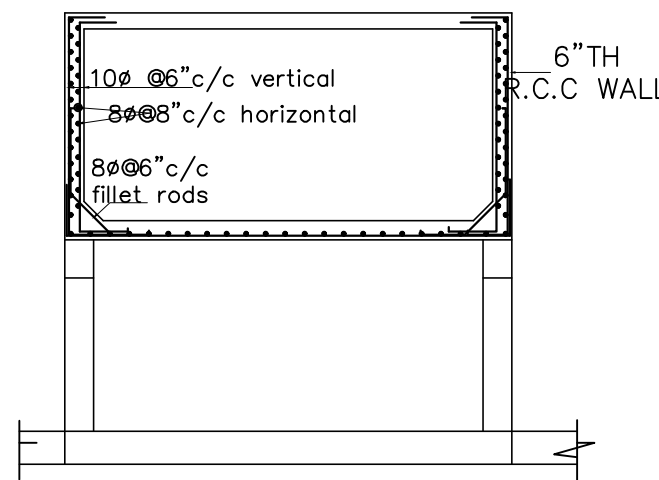

TYPICAL R.C.C. DETAILS

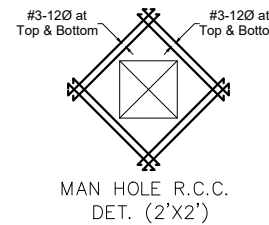

MAN HOLE R.C.C. DET. (2' x 2')

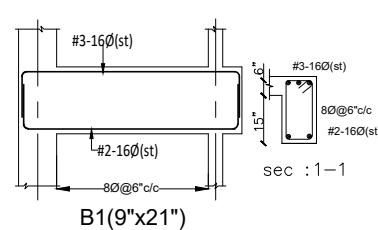

B1(9"x21")

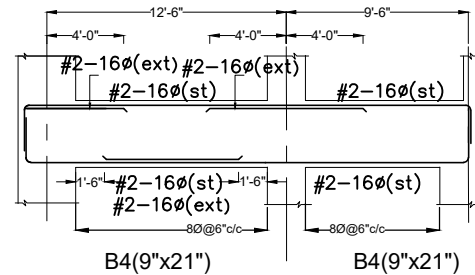

B4(9"x21") B4(9"x21")

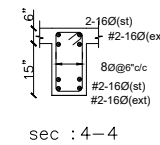

sec : 4-4

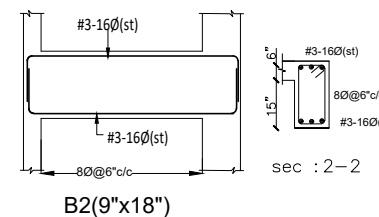

B2(9"x18")

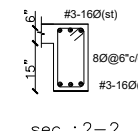

sec : 2-2

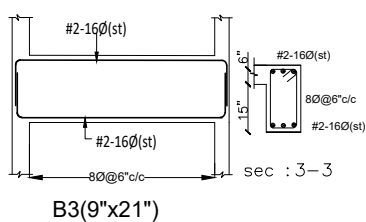

B3(9"x21")

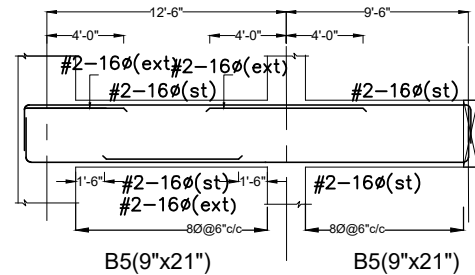

B5(9"x21") B5(9"x21")

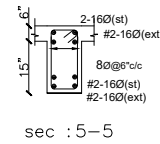

sec : 5-5

NOTE :

- USE M25 (1:1.5:2) GRADE CONCRETE FOR COLUMNS & M20 (1:1.5:3) FOR BEAMS & SLAB
- USE FE500 GRADE TOR STEEL.
- PROVIDE CLEAR COVER OF 1.5" FOR COLUMNS, 1" FOR BEAMS & 3/4" FOR SLAB
- PROVIDE 1" CAMBER AT FREE END FOR CANTILEVER BEAMS & SLABS.
- IN SLAB EXTEND -VE STEEL UPTO 0.30L FROM FACE OF SUPPORT.
- DO NOT PROVIDE EXTRA REINFORCEMENT AT SIMPLY SUPPORTS.
- LAP LENGTH 48 D ( D- IS THE DIA OF THE BAR) IN COMPRESSION.
- LAP LENGTH 52 D( D- IS THE DIA OF THE BAR) IN TENSION.
- ONLY FIGURED DIMENSIONS SHALL BE FOLLOWED.
- ALL THE DIMENSIONS ARE IN INCHES & FEET.
- DO NOT SCALE THE DRAWING.
- REFER ARCHITECT DRAWING FOR CENTER LINE DIMENSIONS.
- LAP LENGTH INCLUDING ANCHORAGE VALUE OF HOOKS FOR BARS IN FLEXURAL TENSION SHALL BE  $L_d$  OR 300 WHICH EVER IS GREATER. THE STRAIGHT LENGTH OF THE LAP SHALL NOT BE LESS THAN 150 OR 200mm, WHEN BARS OF TWO DIFFERENT DIAMETERS ARE TO BE SPLICED, THE LAP LENGTH SHALL BE CALCULATED ON THE BASIS OF DIAMETER OF THE SMALLER BAR.
- LAP / DEVELOPMENT LENGTH FOR MAIN REINFORCEMENT BARS FOR DIFFERENT GRADES OF CONCRETE MIX SHALL BE AS FOLLOWS:  

STEEL GRADE	M20	M25	M30	M35
Fe 415	47	d 41	d 38	d 34
Fe 500	57	d 49	d 46	d 40

WHERE d IS THE DIAMETER OF THE BAR.

PRODUCED BY AN AUTODESK STUDENT VERSION

PRODUCED BY AN AUTODESK STUDENT VERSION

DESCRIPTION		DATE
Client	MODI PROPERTIES & INVESTMENTS PVT.LTD	
Project	RESIDENTIAL PROJECT FOR (B & C) MAY FLOWER GRANDE AT MALLAPUR.	
STRUCTURAL CONSULTANT	KULKARNI CONSULTANTS STRUCTURAL ENGINEERS, ARCHITECTS & PROJECT CONSULTANTS #216, KUBERA TOWER'S, NARAYAN GUDA, HYDERABAD. CONTACT NO'S:- 04023223891, 09246343724, 09246343720.	
DATE	9-8-2017	BLOCK (E) FIRE STATIC TANK
DEALT BY	PAWAN	TITLE: OVER HEAD TANK SLAB DETAILS
DESIGN BY	SRIKANTH	DWG. NO. KC/MBC/SD/E/
CHECKED & APPROVED	KULKARNI	REV. No.