

TYPE - BB1

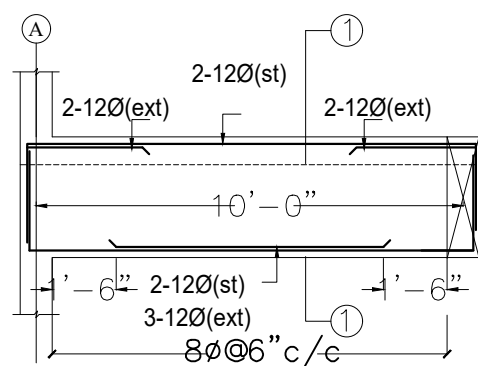

B1(6"x 17")

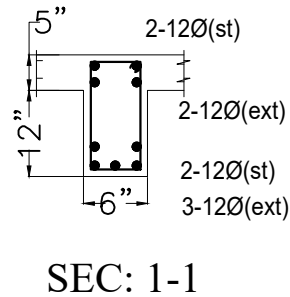

SEC: 1-1

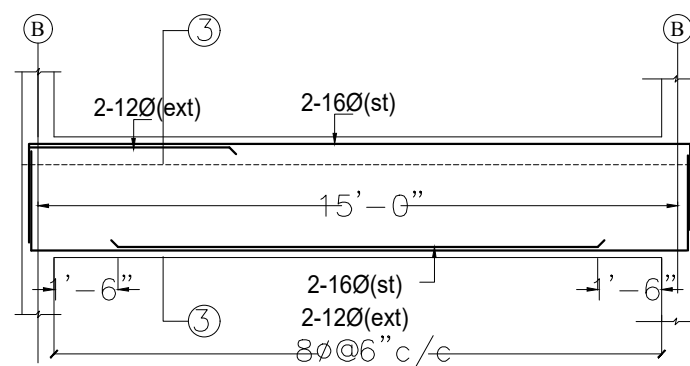

B3(6"x 17")

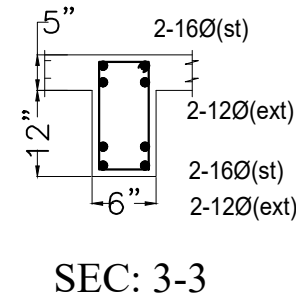

SEC: 3-3

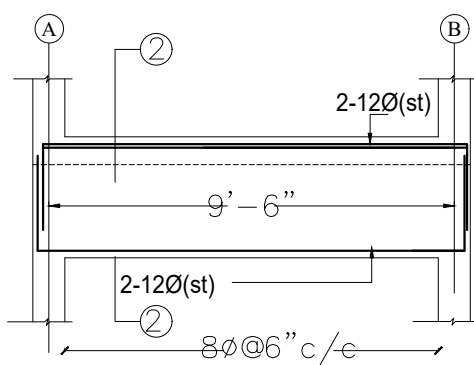

B2(6"x 17")

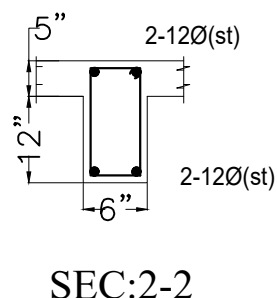

SEC:2-2

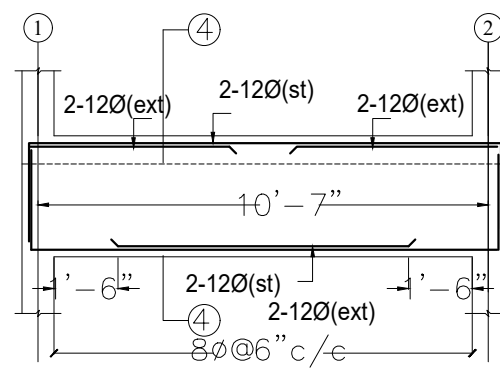

B4(6"x 17")

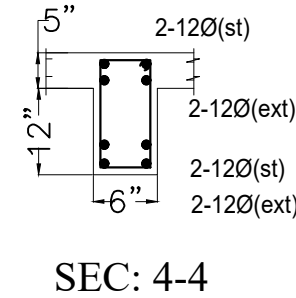

SEC: 4-4

General Notes : --

1. Use M25 (1:1:2) grade for columns & M20 (1:1.5:3) for footings, slab & Beams
2. Use FE 500 grade for steel.
3. Provide clear cover of 2" for footings & 1.5" for columns.
4. S.B.C of the Soil is taken as 350kn/m2.
5. Footings are design for Ground & 1st floor.
6. Provide clear cover of 1" for beams
7. Read horizontal beams from left to right & vertical from bottom to left.
8. crank +ve bars at L/4 th of span & extend -ve bars L/5 th of span.
9. Do not over lap bottom rods at center and top rods at support.
10. Slab thickness

DESCRIPTION	DATE
-------------	------

GOOD FOR CONSTRUCTION	
-----------------------	---

Client	MODI PROPERTIES & INVESTMENTS PVT.LTD
--------	---------------------------------------

Project	NILAGIRI ESTATE AT RAMPALLY, PHASE - II
---------	---

STRUCTURAL CONSULTANT	 <b>KULKARNI CONSULTANT'S</b> STRUCTURAL ENGINEERS, ARCHITECTS & PROJECT CONSULTANT'S #216, KUBERA TOWER'S, NARAYAN GUDA, HYDERABAD. CONTACT NO'S:- 04023223891, 09246343724, 09246343720.
-----------------------	--

DATE	28-11-2016	TYPE -BB1 (SINGLE)	
DEALT BY	PAWAN	TITLE:	STAIR CASE HEAD ROOM SLAB DETAILS
DESIGN BY	MD VIQHAR AHMED		
CHECKED & APPROVED	KULKARNI	DWG. NO.	REV. No. 0