

SECTION B-B

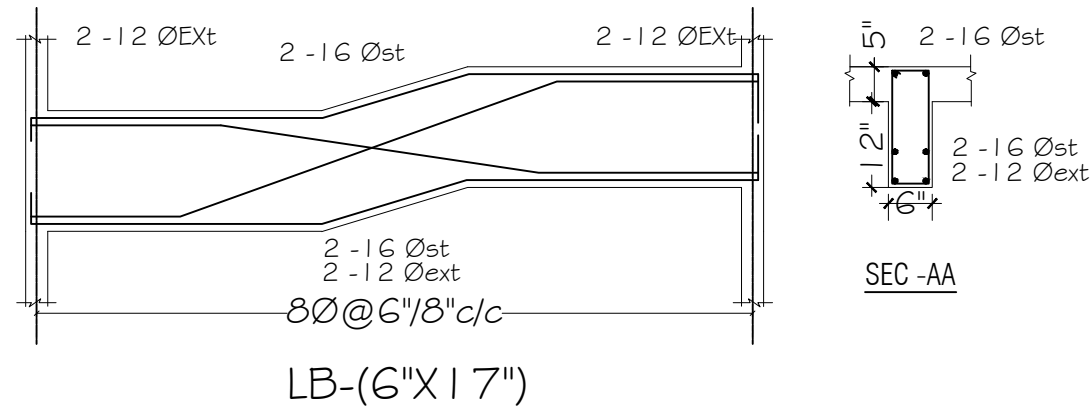

LB-(6"X17")

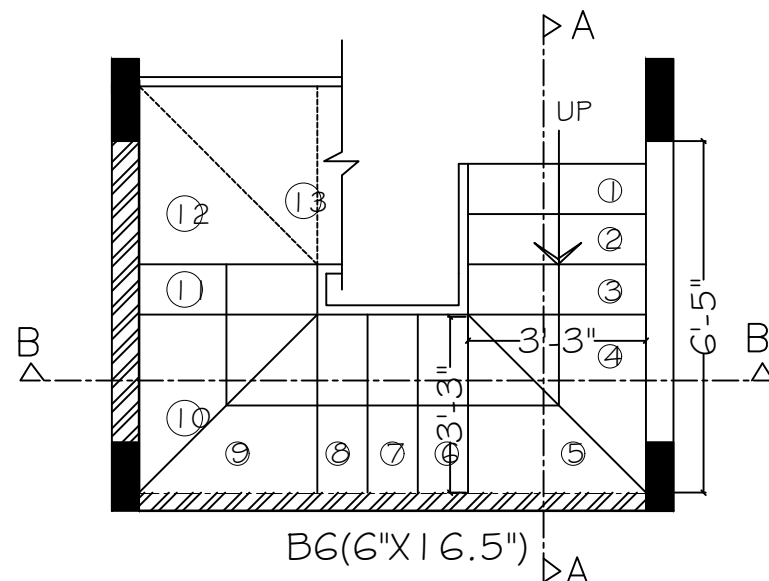

STAIRCASE PLAN

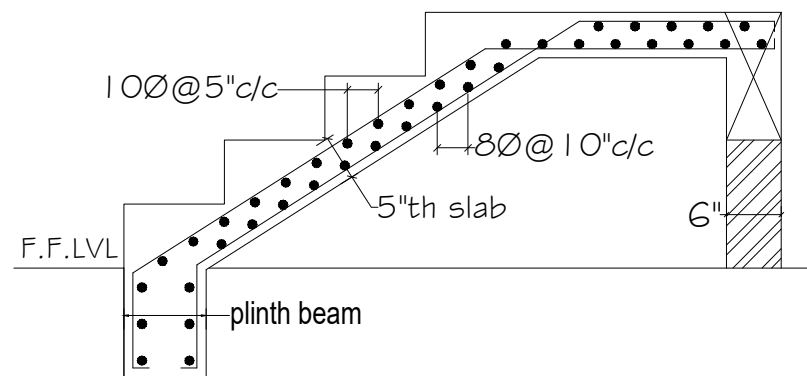

SECTION-A-A

General Notes :--

1. Use M25 (1:1:2) grade for columns & M20 (1:1.5:3) for footings, slab & Bams
2. Use FE415 grade tor steel.
3. Provide clear cover of 2" for footings & 1.5" for columns.
4. S.B.C of the Soil is taken as 400kn/m2.
5. Footings are designen for Ground + 2ND floor
6. Provide clear cover of 1"for beams
7. Read horizontal beams from left to right & vertical from bottom to left.
8. crank +ve bars at L/4 th of span & extend -ve bars L/5 th of span.
9. Do not over lap bottom rods at center and top rods at support.
10. Slab thickness

Project :--

PROPOSED RESIDENTIAL DUPL
BANGLOWS OF [PHASE- VI
M/s. MODI PROPERTIES AT
CHERLAPALLY & SHAMIRPET

Sheet Title :--

WEST FACING PLOT
PLOT No.:--TYPE -(C)
STAIRCASEDETAILS

Drawing no:--	NORTH
Date :-- 18-12-08	
Scale :--	
Dealt By:-- LAXMAN	
Chk by:-- M. Dattatreya rao.	

Architect's:--

Architectural Asso

8-1-383, R . P .ROAD, Sec

Consultant's:--

Kulkarni Consultant's

Stur. Engineer's & Project Consultar

#216, Kubera Tower's, Narayan Guda

NOTE-

1. Refer architects drawing for for thread , riser, & staircase width